PC17(WT17) Industrial Pressure Sensor



- Piezoresistive silicon chip employed
- Perfect long term stability
- MEMS technology
- CE certificate
- Sensor diameter: 17mm

PC17(WT17) industrial pressure sensor is a standard and most popular sensor applied in air and liquid pressure measuring. A high sensitivity silicon pressure chip is employed in the sensor. The housing is filled with oil for pressure transmission. The most important specification for industry application is long term stability. PC17(WT17) sensor is designed for industry application with perfect long term stability.

Diaphragm and pressure range

The diaphragm diameter has tight relation with pressure measured. Low pressure requires large diameter and high pressure needs small diameter. This is caused by oil expansion during temperature changing. It creates internal pressure due to the resistance of the diaphragm. The smaller diaphragm will create large internal pressure, and it is difficult to make zero compensation.

Caution

Please do not touch the diaphragm by finger and other hard objects, or it may be damaged.

Pressure range

Pressure range	-100kPa, 10kPa, 35kPa, 70kPa, 100kPa, 250kPa, 400kPa, 600kPa, 1MPa, 1.6MPa, 2.5MPa, 4MPa, 6MPa, (bar and psi unit available)		
Pressure reference	Gauge pressure		
Overpressure	300%F.S.		

Output signal

Output	100mV(Typical)		
--------	----------------	--	--

Specification

Accuracy (linearity, repeatability and hysteresis)	±0.25%F.S. (Typical)		
Excitation	1.5mA (Typical) 5VDC 10VDC		
Compensated temp.	Without temperature compensation		
Operating temp.	-40-125°C		
Storage temp.	-40-125°C		
Insulation resistance	>200Mohm/250VDC		
Bridge resistance	Min.	Max.	Unit
	2600	5500	ohm
Long term stability	≤0.2%F.S.S/year		
Vibration	20g (20-5000HZ)		
Oil filling	Silicon oil (Typical) Olive oil available for sanitary application		
O-ring	NBR, Viton		
Housing and diaphragm	Stainless steel 316L		
Pin connection	Kovar pin (0.6um Gold platted)		
Weight	11g(approx)		

Pin connection

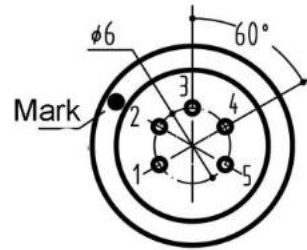
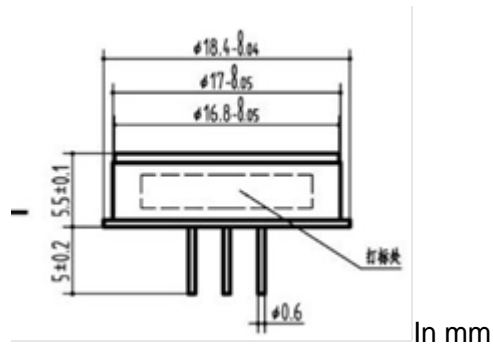

Pin	Connection
3	excitation+
1 or 5	excitation-
2	output+
4	output-

How to order

PC17(WT17) XX-XX-XX-XX

Pressure range

Please write directly

Pressure reference

G: gauge pressure

Electrical Connection

P: pin connection

Excitation

C1: 1.5mA

C2: 10V

C3: 5V